



TASKBOA[®] X LEGLESS[®] STACKER

Introducing the new TASKBOA[®] 3000

The shortest 3000lb counterbalanced unit ever made with tilting carriage will be available June 1st 2019 with the following features as standard.



The NEXSYS system offers opportunity charging and is the ultimate battery combination for compact counterbalanced stackers.

The Delta Q charger is absolute state of the art. During our own testing and evaluation over the last 12 months, we have been able to bring the unit up to a 50% battery charge in less than 40 minutes – allowing an operator to charge the unit during a meal break and continue using the equipment a short time later.



NEW 3000lbs Capacity.

The shortest 3000lb capacity counterbalance unit ever made.



Up to 138" Lift Height.

Available in 98", 118" and 138" lift heights with further options for full-free lift.



Proportional Control.

Users have more control with the proportional lower function.



NEXSYS TPPL Technology.

Thin Plate Pure Lead batteries are completely maintenance free.



Delta-Q Charger.

Built-in, state of the art, intelligent fast charger.



Power Steering.

Electric power steering enhances maneuverability.



Single Phase Charge.

Super fast charging via a standard 110v wall socket.



Opportunity Charge.

Designed to rapidly charge in applications where charging is intermittent between use.



Supported.

Supported by Enersys representatives throughout the USA and Canada.

TASK

EMAIL: INFO@TASKFORKLIFTS.COM

WEB: TASKFORKLIFTS.COM

CALL US: (972) 522 7610

• DALLAS • SYDNEY • MELBOURNE • BRISBANE • ADELAIDE • SHANGHAI • SINGAPORE •

+ TASKBOA® 3000X

LEGLESS® STACKER

LEGLESS® STACKER.

This Legless® Stacker is the ultimate stacker in accessibility and efficiency. The compact size of the BOA allows operators to work in narrow, tight racking and aisles widths; without sacrificing capacity at lift heights.



2200- 3000
Lbs Capacity.



98" -138"
Lift Heights.



Proportional
Control.



Power
Steering.



Opportunity
Charging.



110v Internal
Charger.



INDUSTRIES.



General
Warehousing



Supermarket
Stores



Printing
& Paper



Factory



General
Manufacturing



Retail



Logistics &
Distribution



Food &
Beverages



Carpets &
Flooring



POWER & CONTROL.

The BOA® comes standard with responsive electric power steering to reduce worker fatigue and make it easier for operators to use the stacker in tight areas.

Our ergonomically designed handles, allow users to operate the BOA® using the forward and reverse butterfly control for precise maneuvering and easy access of the lift/ lower and tilt functions for both left and right handed operators.

TASKBOA® X

LEGLESS
STACKER

TASK

EMAIL: INFO@TASKFORKLIFTS.COM

WEB: TASKFORKLIFTS.COM

CALL US: (972) 522 7610

• DALLAS • SYDNEY • MELBOURNE • BRISBANE • ADELAIDE • SHANGHAI • SINGAPORE •



98" - 138"
Lift Height



2200 - 3000
Lbs Capacity



Integrated
Tilt Carriage



Built-In Single
Phase Charger

TECHNICAL INFO

	MODEL	TWO STAGE			TWO STAGE (FULL FREE LIFT)
Lift Height (inches)		98"	118"	138"	98"
A. Rated Capacity at 600mm L.C. (lbs)	2200	2200	2200	2200	2200
	3000	3000	3000	3000	3000
B. Lift Height (inches)		98"	118"	138"	98"
C. Extended Height inches (with load Back Rest)		144.5"	164.5"	184.25"	144.5"
D. Collapsed Height (inches)		70"	80"	89.75"	72"
E. Free Lift (inches)		11.75"			48"
F. Chassis Length to Face of Forks (inches)	2200	48.25"			
	3000	56.5"			
G. Chassis Width (inches)		32.25"			
G1. Width Outside Load Wheels		40.75"			
H. Wheelbase (inches)	2200	38.25"			
	3000	46.25"			
I. Carriage Width (inches)		26"			
J. Chassis Under Clearance (inches)		3.25"			
K. Turning Radius (inches)	2200	43.25"			
	3000	51.25"			
L. Weight Without Battery (lbs)	2200	3858	3902	3946	3858
	3000	4100	4145	4189	4100
M. Right Angle Stacking Aisle (inches)		Dimension F + Load Length + 4"			

TASKBOA[®]X

LEGLESS
STACKER

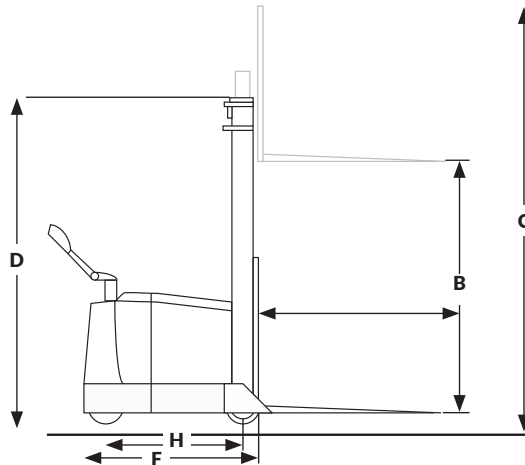

BOA[®] Technical Drawing

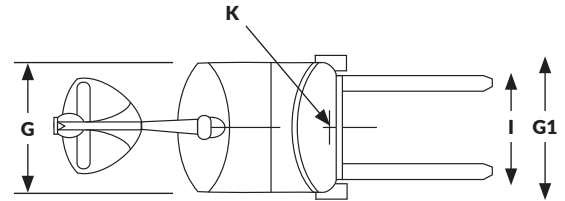

Due to continuous product improvement, specifications are subject to change without notice or obligation. Some systems and features shown are optional at extra cost.

EMAIL: INFO@TASKFORKLIFTS.COM

WEB: TASKFORKLIFTS.COM

CALL US: (972) 522 7610

• DALLAS • SYDNEY • MELBOURNE • BRISBANE • ADELAIDE • SHANGHAI • SINGAPORE •